

Unpack the box and check the parts and accessories prior installation.  
Place all wooden parts on carpeted area to avoid damage or scratch on surface.

**Accessories & Tools required**

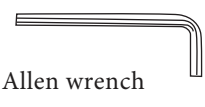

Allen wrench



Long Silver Allen Bolt-Qt-16



Small flat-head screw QT-24



Aluminum bracket Qty- 4



Pegs - Qty 8



PF69.R.C.A-Rubber wood Shelf (36"W x 32" H x 15"D)  
Four Tier with Back Two Adjustable Tiers

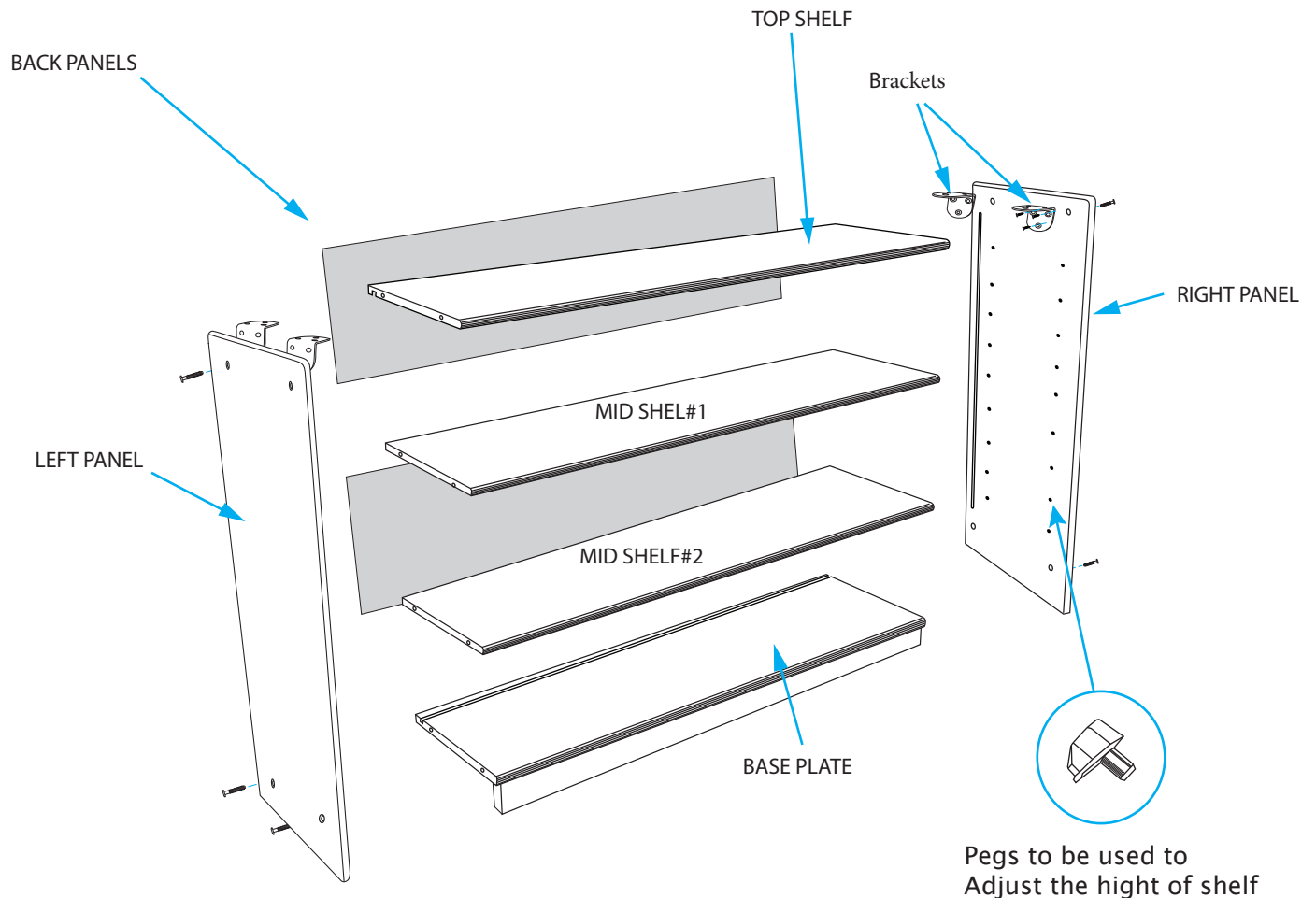

**Step 1:** Install two side panels, right and left on both side of Base Plate with Silver Bolts.

**Step 2:** Install BOTTOM BACK PANEL in the Bottom and side panel grooves.

**Step 3:** Install TOP BACK PANEL in the side panel grooves.

**Step 4:** Install the top shelf as shown with Silver Bolts, Make sure TOP BACK PANEL sets inside the top shelf groove,

**Step 5:** Install Middle shelves setting on Pegs inserted in both side panels at desired height.

\* Mark the notches engraved under side of both middle shelves.

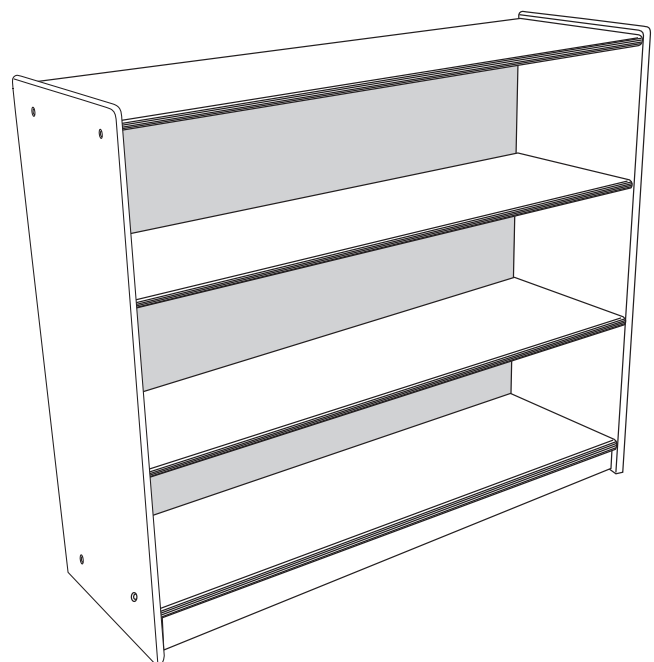

**Complete installation view**